



Level



Pressure



Flow



Temperature



Liquid Analysis



Registration



Systems Components



Service Solutions

Barrier, 1 or 2-channel, without power supply RB223

E-direct

www.e-direct.us



- Space-saving single/dual channel version
- No additional supply voltage needed
- Can be used up to SIL3
- Bidirectional HART® transmission

Application

The passive barrier RB223 is used for the galvanic isolation of active signal circuits (0 to 20 mA) in three applications:

- Transmission from non-Ex to Ex areas e.g for active adjusters, controllers or indicators
- Transmission from Ex to non-Ex areas for connection of active, intrinsically safe circuits to the PLC
- Transmission from Ex to non-Ex areas for supply of intrinsically safe transmitters with non-intrinsically safe transmitter power supply

Measurement principle

The passive barrier transmits signal circuits from the input to the output by galvanic isolation. A HART® signal is also transmitted. The device is available with intrinsically safe input/output. The device is loop-powered and does not need any additional supply voltage of its own.

Certificates: ATEX II (1) GD [EEx ia] IIC/IIB ATEX II (1) GD [EEx ib] IIC/IIB	HART® communication: Built-in resistance for HART® communication 232 Ω
Version: Optional dual-channel version	Signal transmission: - from non-Ex to Ex-areas - from Ex to non-Ex areas

Application Example

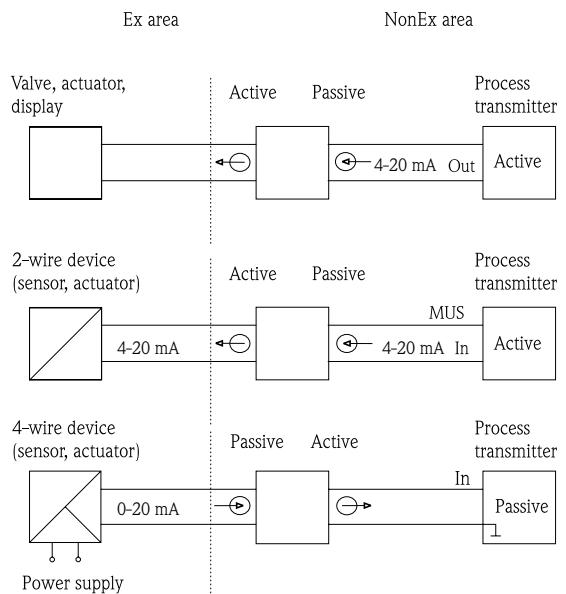

RB223

Technical data

Current transmission direction Non-Ex -> Ex; Input

- Function range 0 to 40 mA (to 22 mA for specified accuracy)
- Effective voltage max. < 26 V for specified accuracy
- Short circuit current $I_{\max} = 100 \text{ mA}$
- Limiting voltage $U_{\max} = 30 \text{ V}$

Current transmission direction Non-Ex -> Ex; Output

- Function range 0 to 40 mA (to 22 mA for specified accuracy), max. current depends on load
- Load load resistance max. 0 to 600 Ω
- Type of protection intrinsically safe according to ATEX:
 - Max. voltage: $U_o \leq 28 \text{ V}$
 - Max. current: $I_o \leq 93 \text{ mA}$;
 - Max. power: $P_o \leq 660 \text{ mW}$

Current transmission direction Ex -> Non-Ex; Input

- Function range 0 to 40 mA (to 22 mA for specified accuracy)
- Type of protection intrinsically safe according to ATEX:
 - Max. voltage: $U_i \leq 30 \text{ V}$,
 - Max. current: $I_i \leq 100 \text{ mA}$,
 - Max. power: $P_i \leq 750 \text{ mW}$

Current transmission direction Ex -> Non-Ex; Output

- Function range 0 to 40 mA (to 22 mA for specified accuracy), max. current depends on load
- Load load resistance max. 0 to 600 Ω

Galvanic isolation

- Test voltage > 1.5 kV AC between input and output
> 1.5 kV AC between the channels

Power supply

- Starting current own consumption < 50 μA
- Voltage drop < (1.9 V + 400 Ω x current loop) for nonEx -> Ex
< (3.9 V + 120 Ω x current loop) for Ex -> nonEx
- Power loss < 0.2 W at 20 mA (per channel) without HART®
< 0.3 W at 20 mA (per channel) with HART®

Accuracy

- Current transmission < $\pm 10 \mu\text{A} + 0.15\%$ from measured value
- Temperature drift $\pm 0.01\% / 10 \text{ K}$

Operating conditions

- Ambient temperature -4 to +140°F (-20 to +60°C)
- Storage temperature -4 to +185°F (-20 to +80°C)
- Climate class to IEC 60 654-1 class B2
- Relative humidity 95% without bedewing
- EMC interference immunity to IEC 61 326 (industry) and NAMUR NE21

Mechanical construction

- Dimensions W x H x D: 0.89" x 3.78" x 4.41"
(22.5 x 96 x 112 mm)
- Weight approx. 0.33 lbs. (150 g)

General

- Communication HART® protocol: bi-directional possible
- Frequency response 650 Hz for 500 Ω load for nonEx -> Ex
1300 Hz for 500 Ω load for Ex -> nonEx

Approvals

- Ex approvals ATEX II (1) GD [EEx ia] IIC/IIB
ATEX II (1) GD [EEx ib] IIC/IIB
- SIL Can be used up to SIL3

RB223

Dimensions in inches (mm)

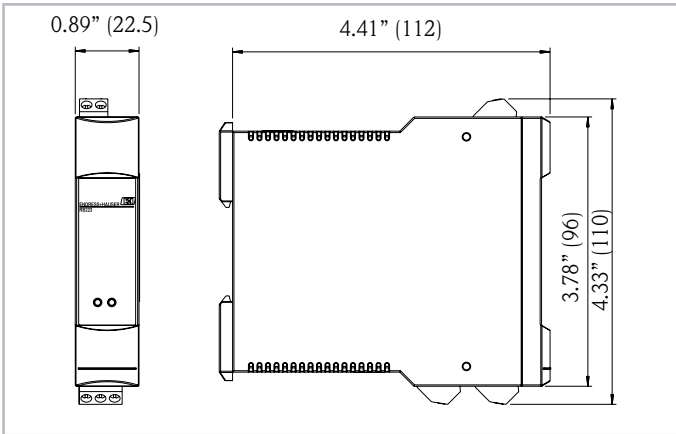

Electrical Connection

Connection RB223, Ex->Non-Ex 2 channel

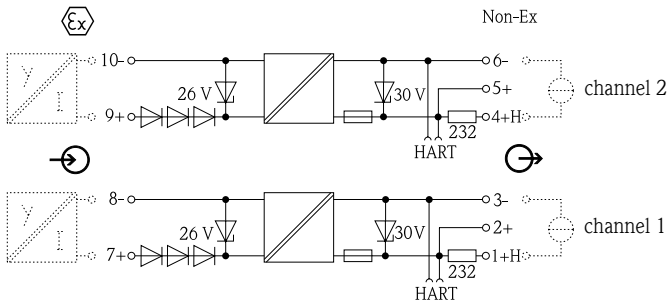

Connection RB223, Non-Ex->Ex 2 channel

